

# **Build an RF Coax Shield Current Probe**

[w6nbc.com/slides.html](http://w6nbc.com/slides.html)



# RF Probe

**Stray RF in the radio shack**

**owenduffy.net**

<https://owenduffy.net/module/icm/#:~:text=An%20approach%20to%20measurement%20Common%20mode%20current%20can, half%20wave%20detector%20driving%20a%20high%20impedance%20voltage%20meter.>

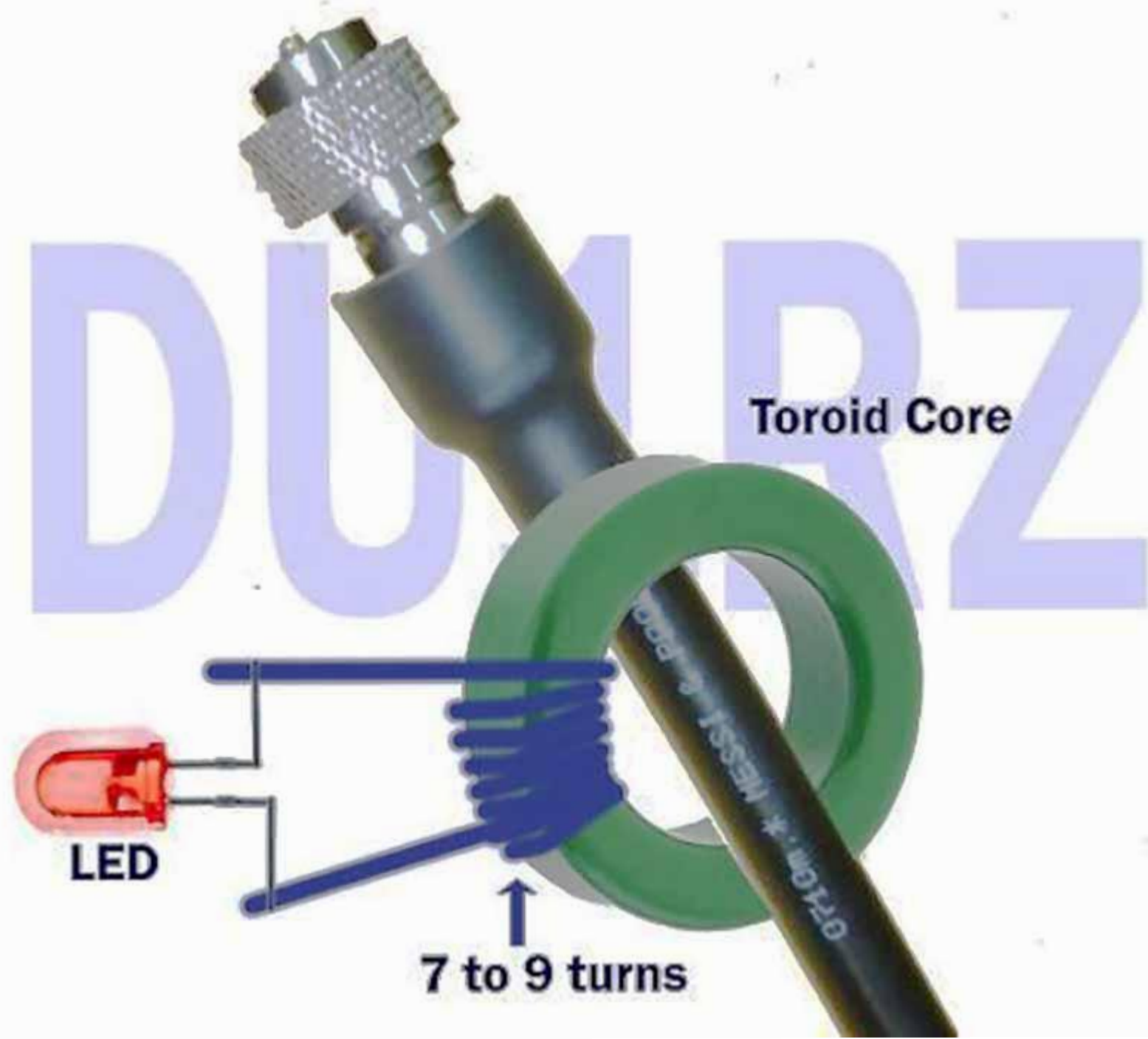

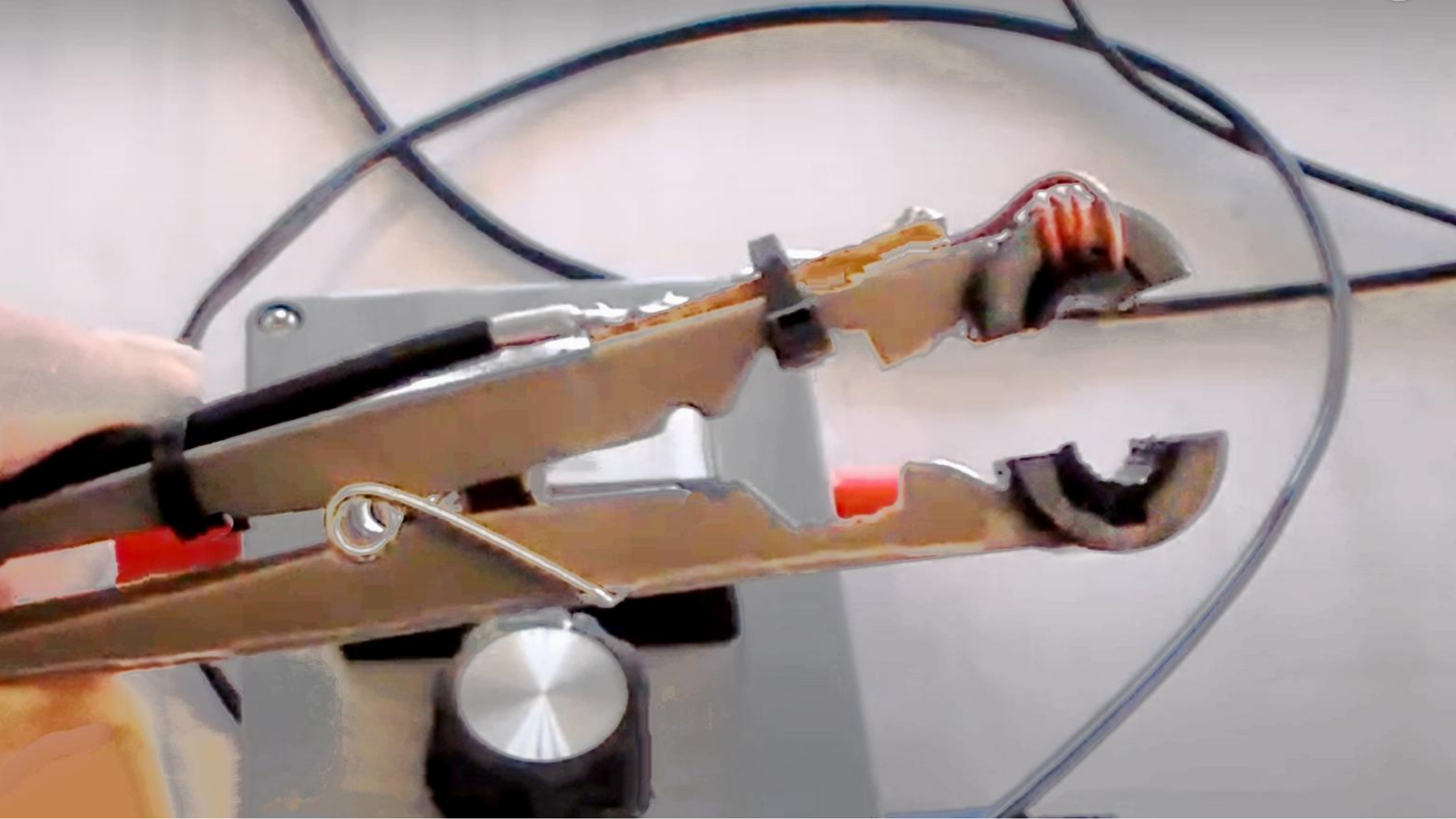



**MFJ-853H, CLAMP-ON,  
MINI RF CURRENT METER, HI-PWR**

**\$109.95**

**Clamp-on ferrite  
choke with an added  
pickup coil & meter**



**The W60EK  
Version  
With and  
Without 3D  
Printed Cover**

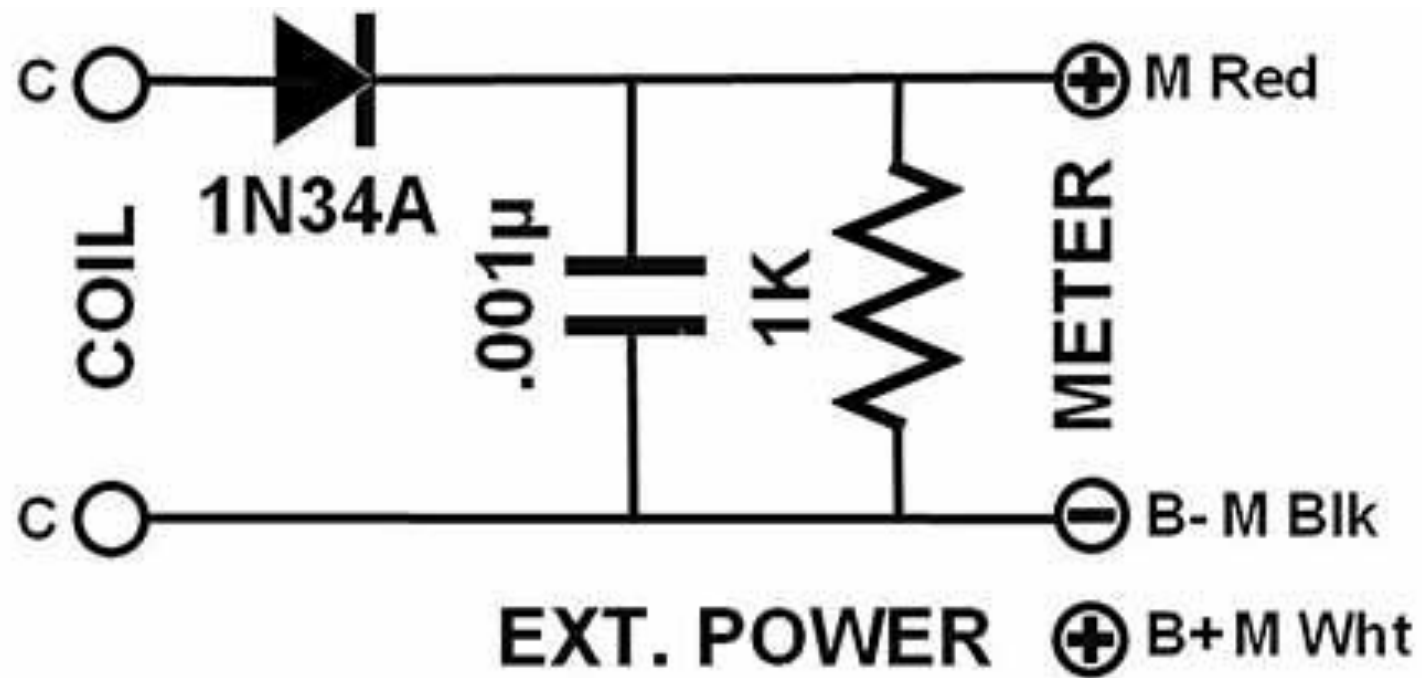
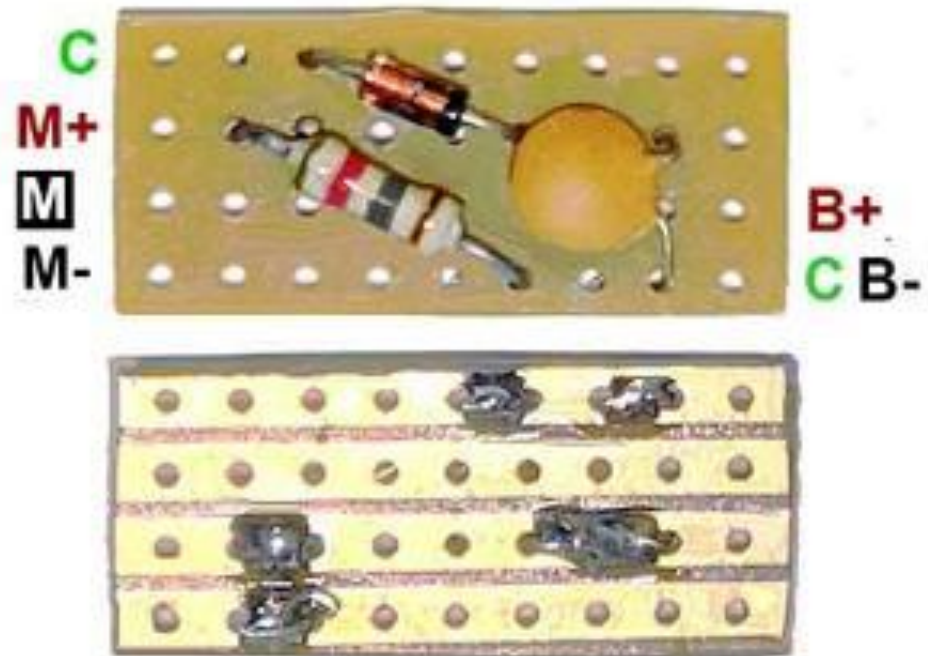

[w6nbc.com/slides.html](http://w6nbc.com/slides.html)

# Bill of Materials

w6nbc.com  
/slides

1	Snap-on mix 43 Ferrite choke for RG-8, RG-213 size coax. (0.405 in.)	e.g. Fair-Rite 0443164151 snap-in, Palomar Engineers FSB43-1/2, ID=1/2" or similar
10 turns	Insulated magnet wire, AWG 24 (or smaller)	Electronic parts supplier
1	3-digit digital voltmeter, 3-wire 100V version (see text)	Amazon, <a href="#">EBay</a> , mpja.com, Walmart, surplus electronics dealers
1	1N34 diode	Electronic parts supplier
----	100 mil linear copper strip perfboard	Electronic parts supplier
1	2 <a href="#">cell</a> (6V) 2032 coin cell holder with cells and switch	<a href="https://www.amazon.com/dp/B092VFFCR8?psc=1&amp;ref=ppx_yo2ov_dt_b_product_details">https://www.amazon.com/dp/B092VFFCR8?psc=1&amp;ref=ppx_yo2ov_dt_b_product_details</a> Amazon, <a href="#">EBay</a>
----	3M VHB Double Sided Heavy Duty Outdoor Mounting Tape or sticky squares	Local hardware store, internet
1	3D printed probe cover	<a href="#">.stl</a> 3D printer file: <a href="#">xxxxxx</a>



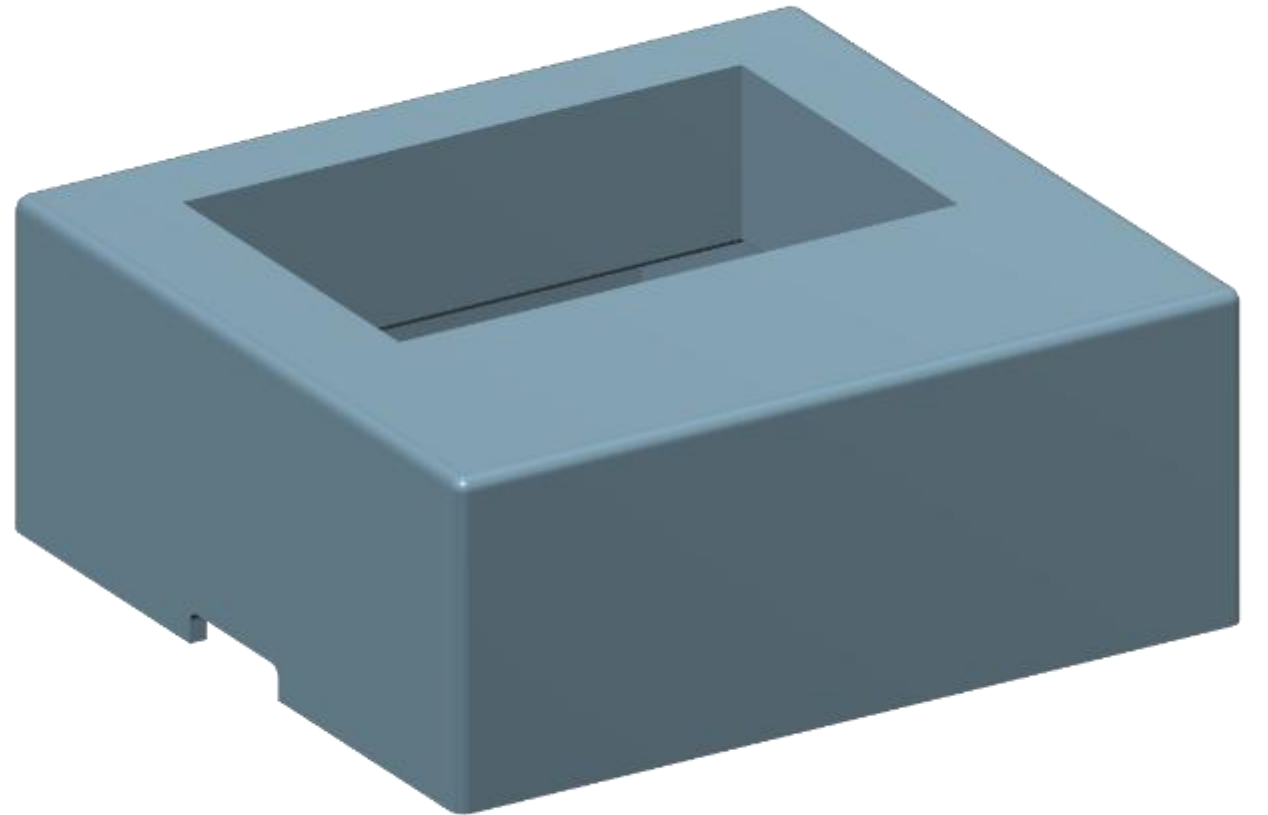
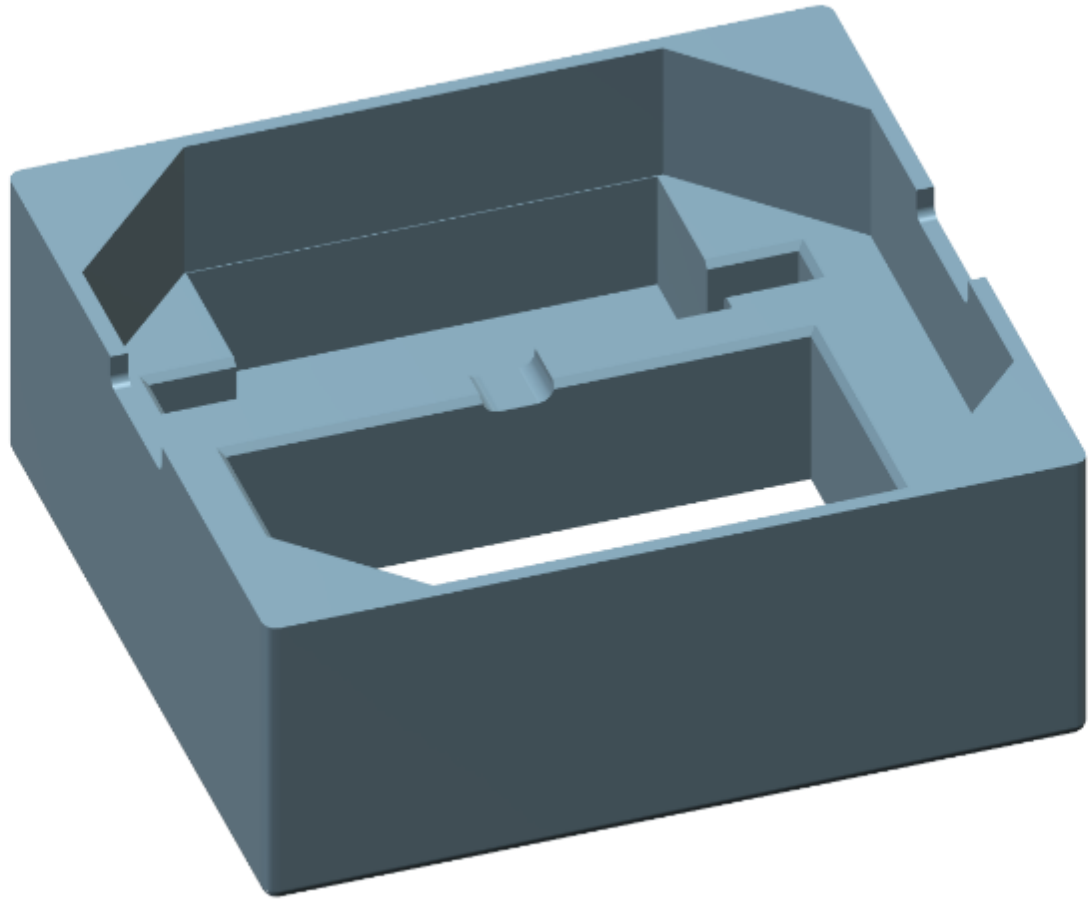

[w6nbcmail@gmail.com](mailto:w6nbcmail@gmail.com)

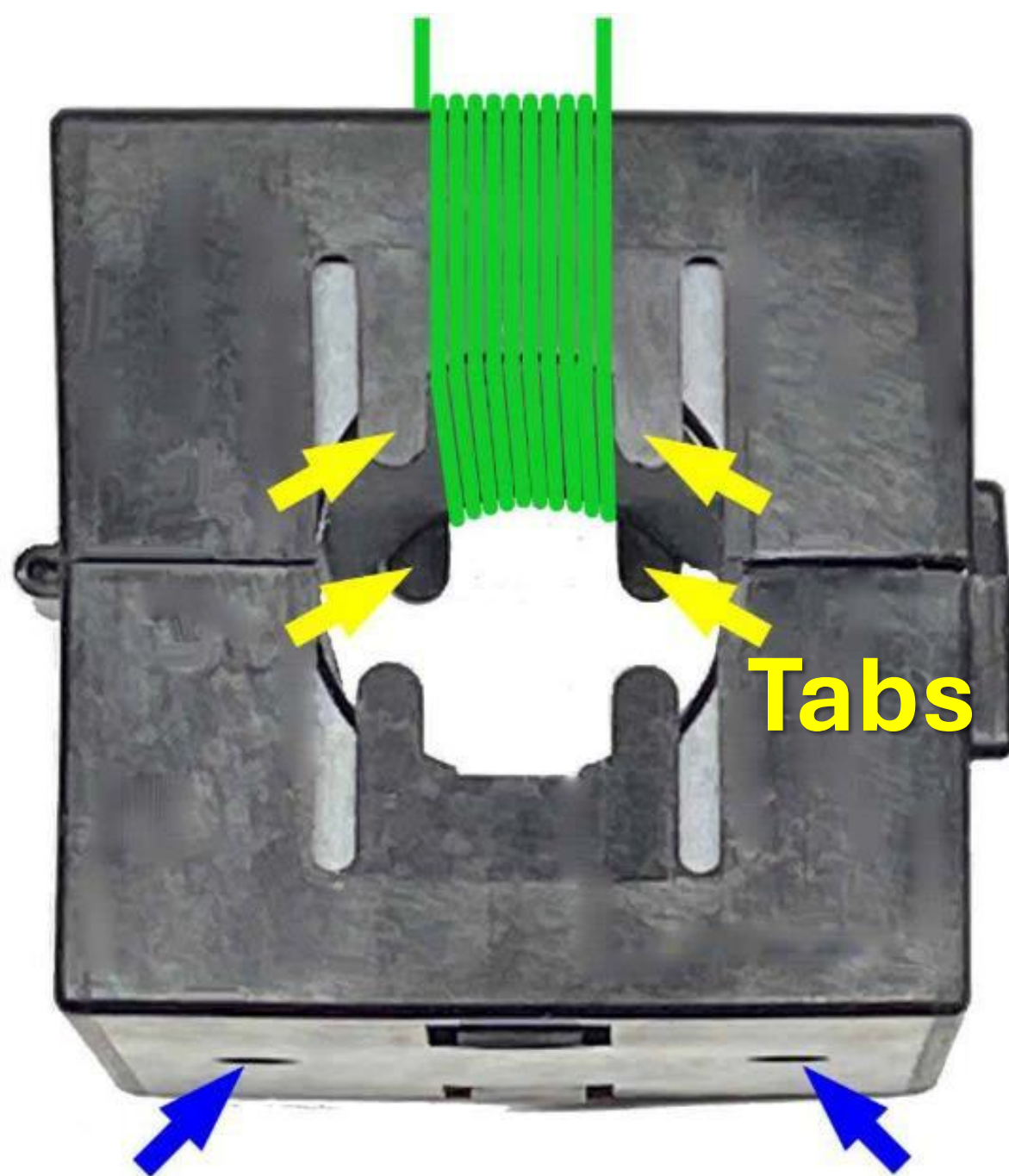

**Fair-Rite**  
**0443154151**  
**for 1/2 in. coax**  
**OK for smaller**  
**coax**

**Tabs**

**Holes**

# **A Better View of Baluns**



# Widespread Balun Myth

“I have a **BALUN** at my antenna,  
I won't get shield current”

# The Need for Baluns is a Consequence of **Skin Effect**

Cross Section of Wire

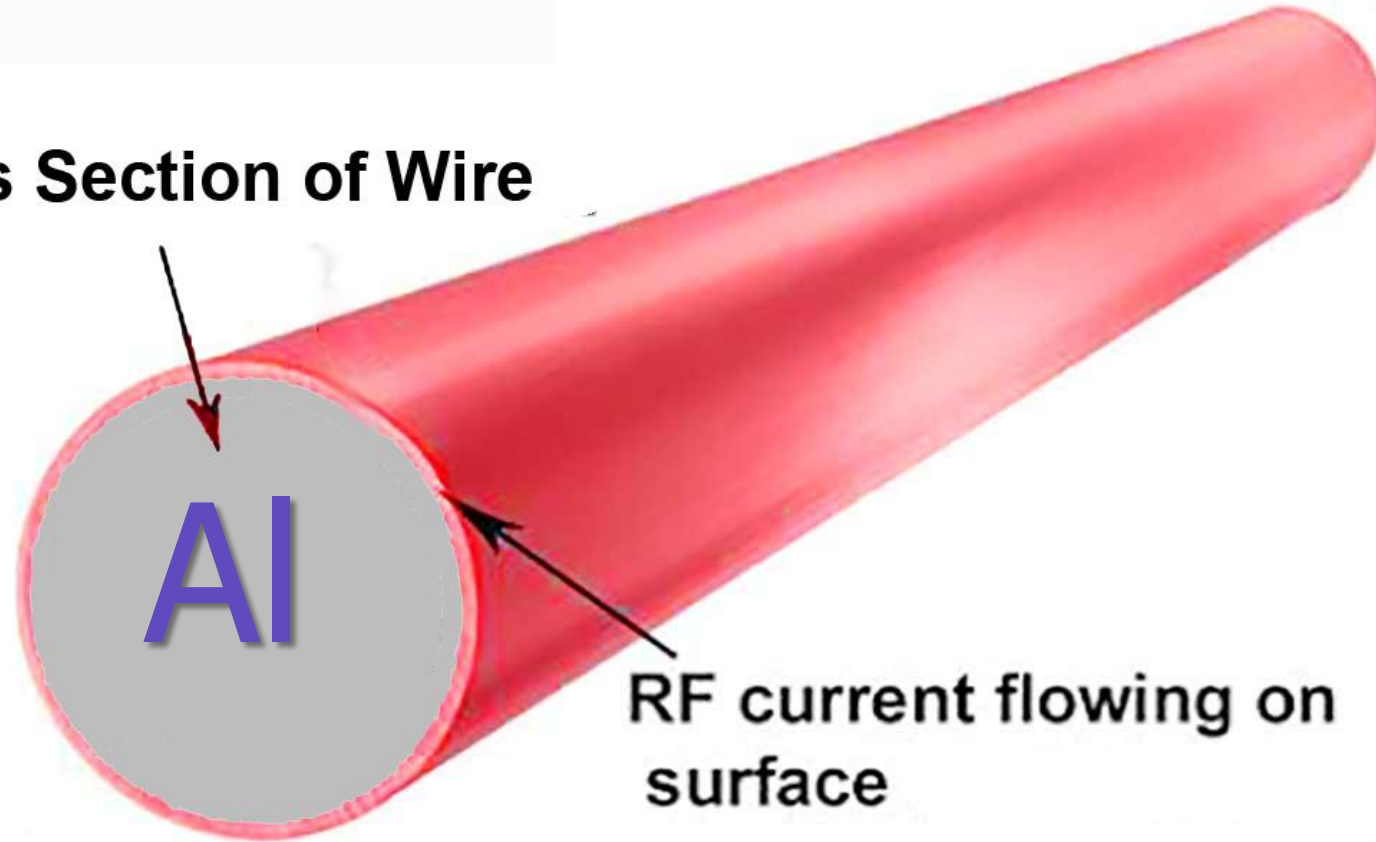

# Surprise -- Coax has 3 wires

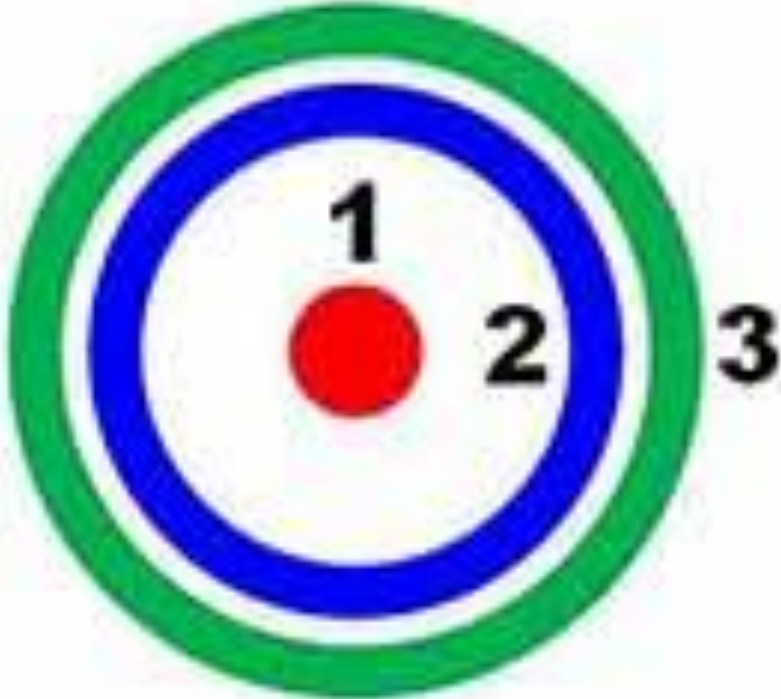
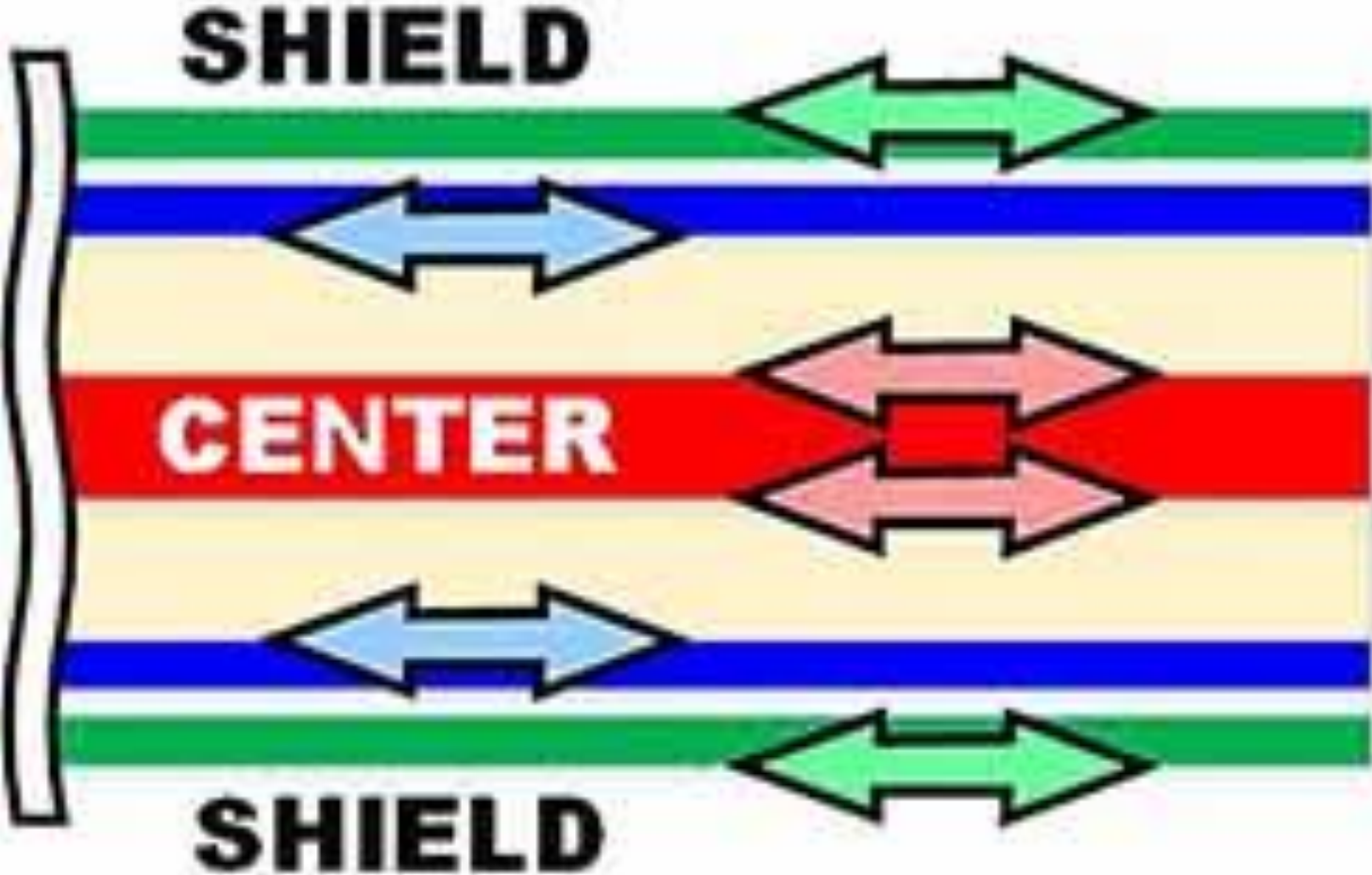

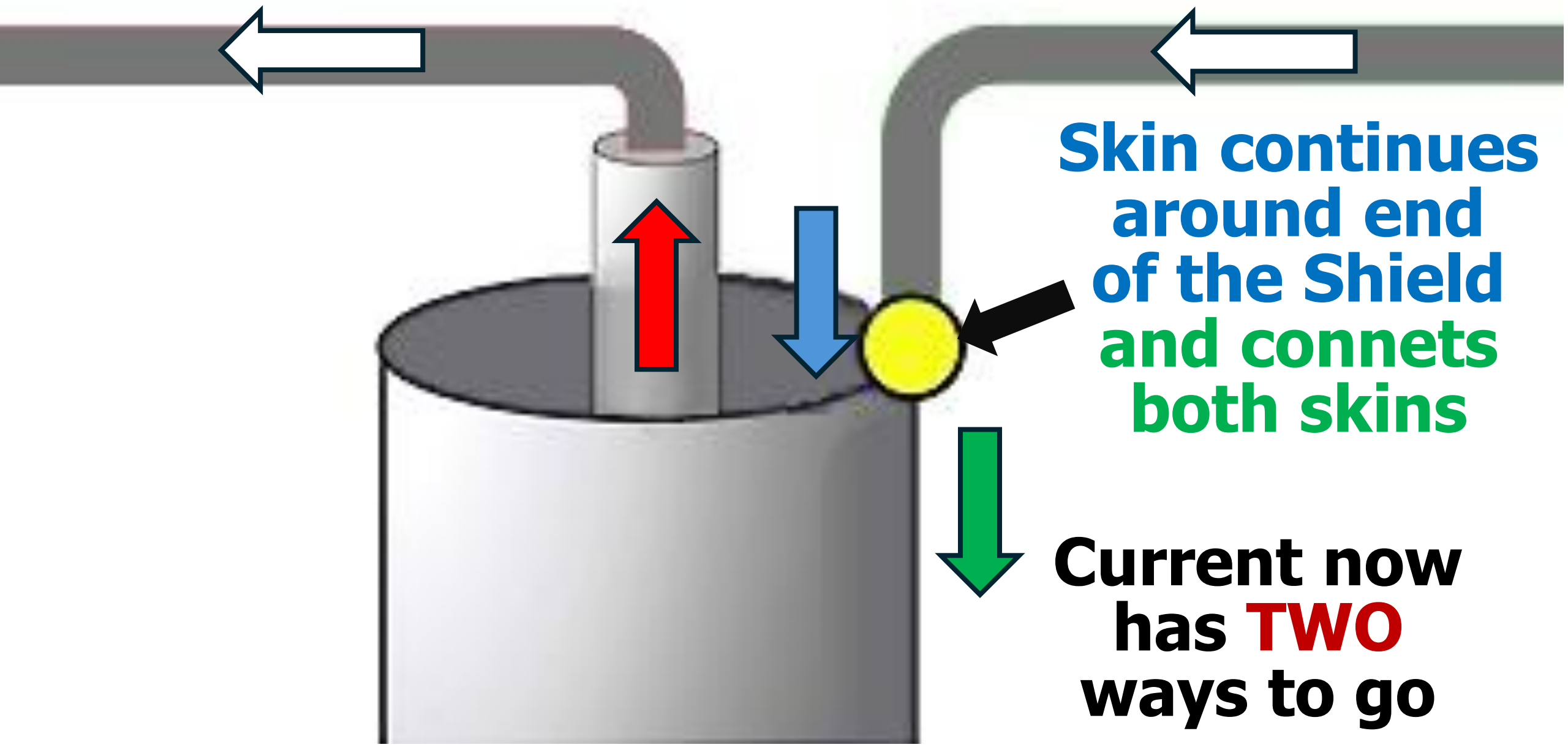

**Skin continues  
around end  
of the Shield  
and connets  
both skins**

**Current now  
has **TWO**  
ways to go**

# Connection at the end of Coax is a Main Source of Shield Current

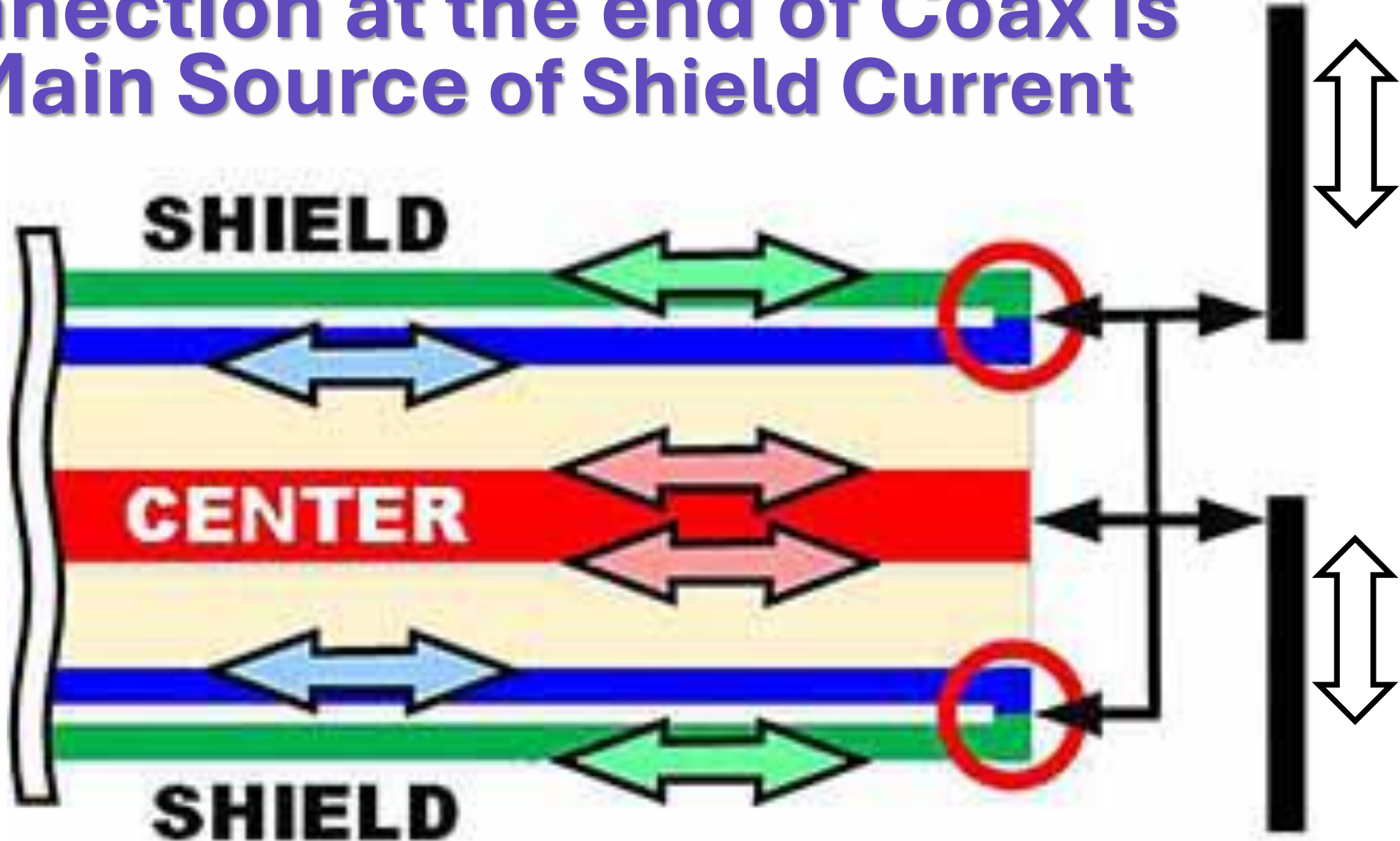



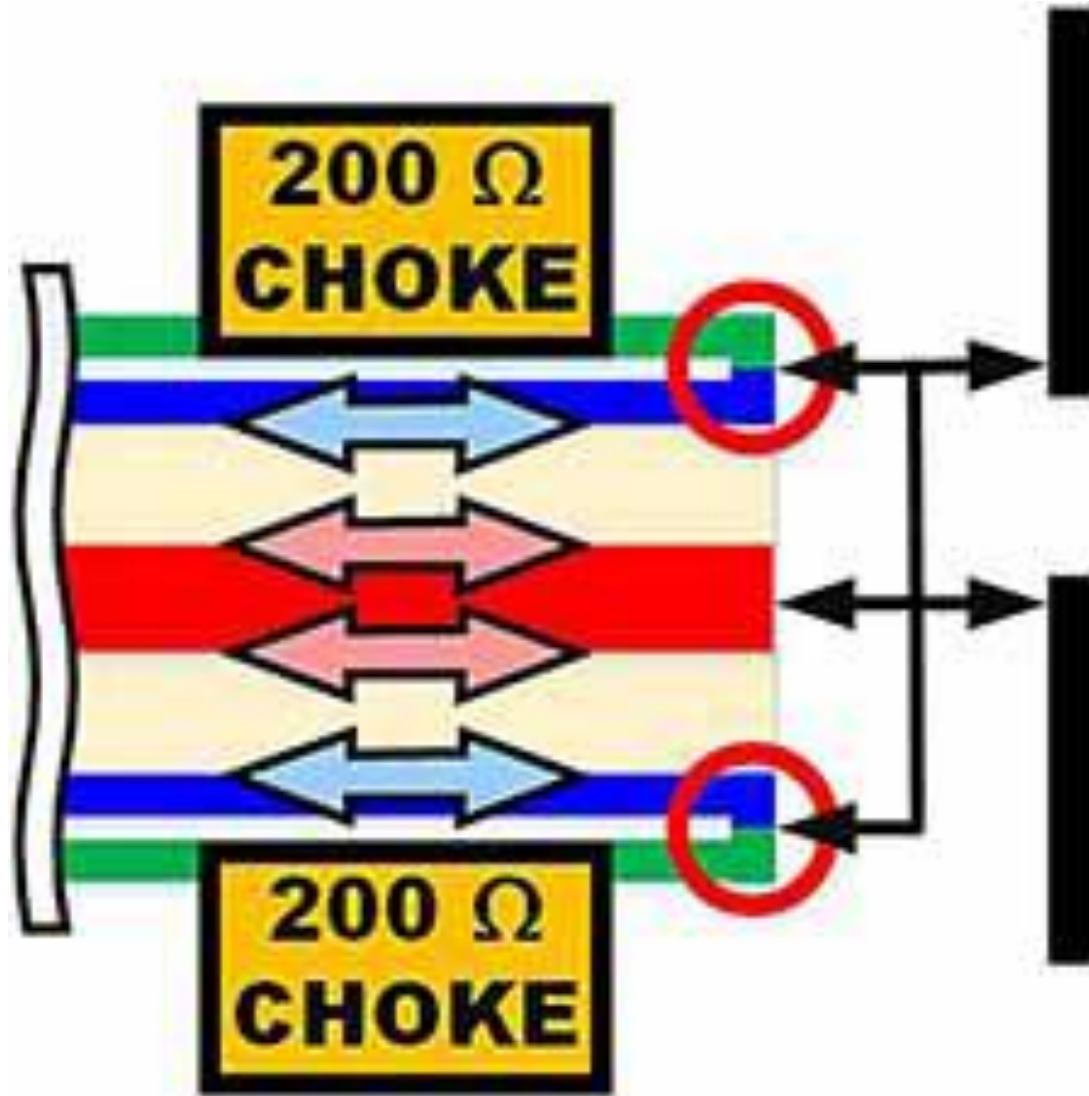

The **PRIMARY** job  
of **ALL** baluns:  
*To Choke Off*  
*“Isolate”*  
the Outside Skin  
*i.e. to “Balance”*  
the Inside Currents

**“Minimum” accepted  
choking impedance**

**200Ω = 4 times**

**50 Ω system impedance**

**OK to use more**

**A secondary job**

**As an impedance  
transformer**

**4:1, 9:1**

# The Big Surprise

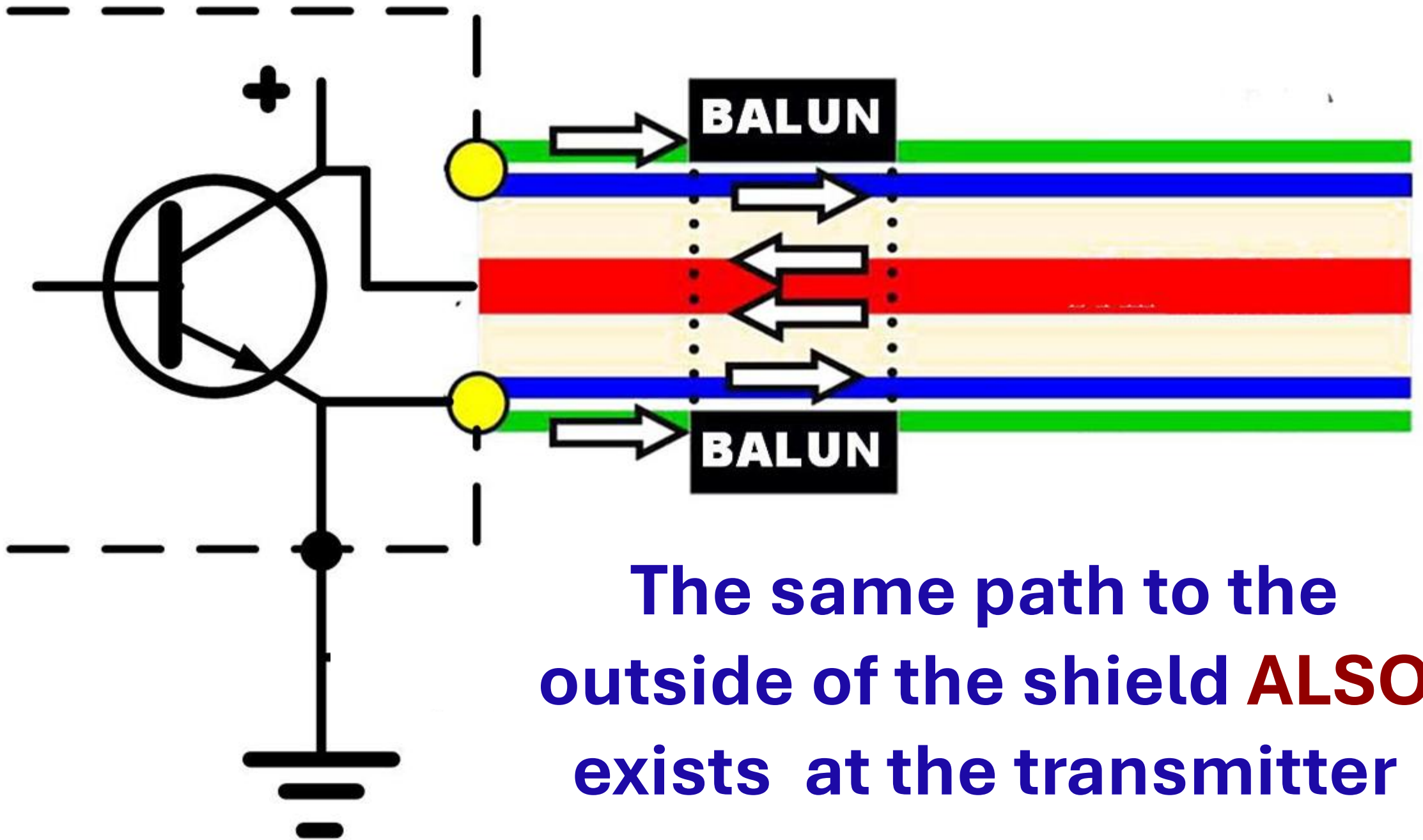

The same path to the outside of the shield **ALSO** exists at the transmitter

# AXIOM

**ANY PLACE** (1) coax ends,

**and also** (2) there's

a balanced source of energy,

**RF can get onto the shield.**

**NOT JUST AT THE ANTENNA**

**Antennas & Transmitters**

***PRIMARY* Sources of Energy**

**Barrels, Switches**

***NOT* Sources of Energy**

**Why we may believe  
we have gotten  
away without  
choking in the shack?**



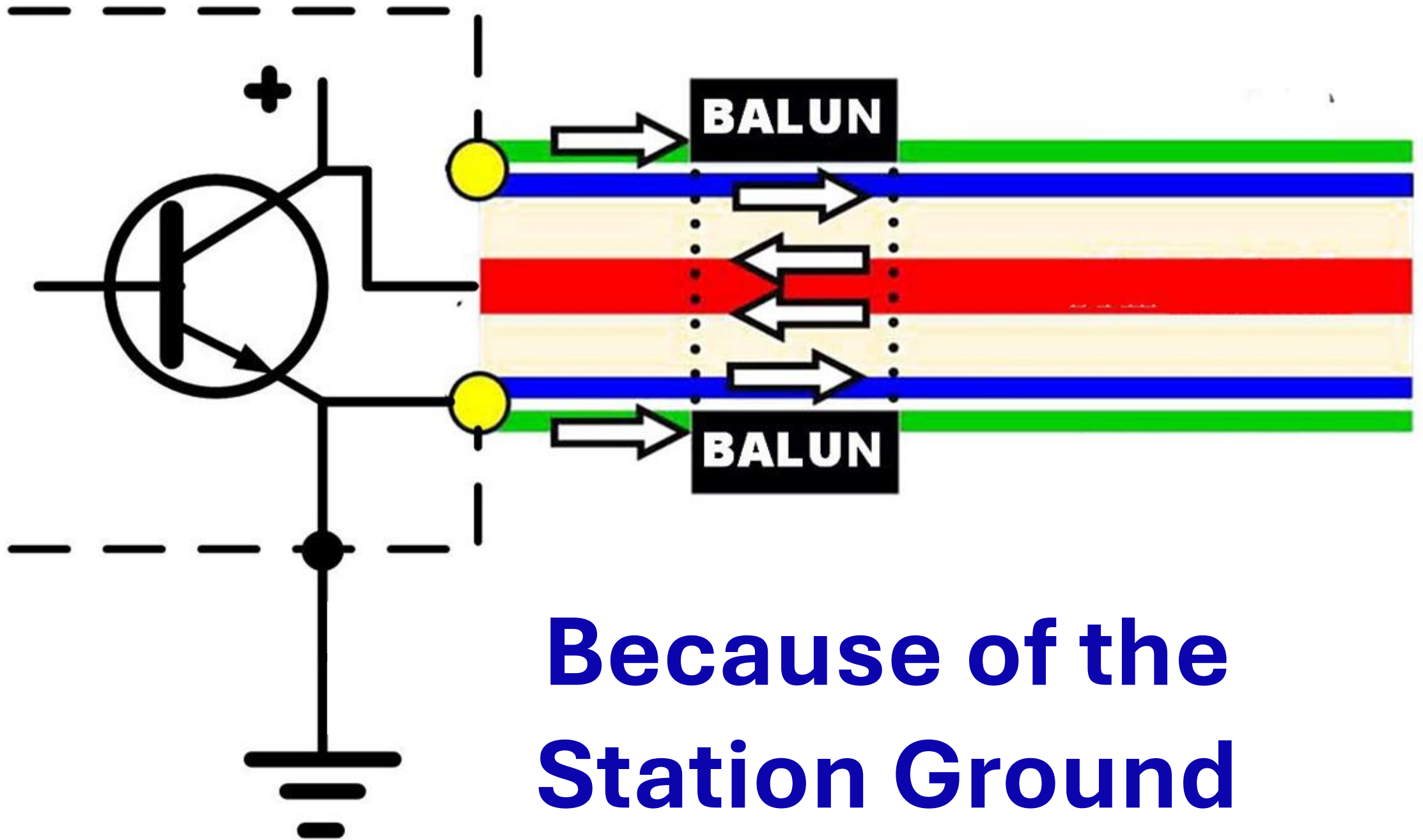

**Because of the  
Station Ground**



H. Ward Silver, N0AX, n0ax@arri.org

## Experiment #144

# The Myth of the RF Ground

Sooner or later, just about every ham who builds an HF station — whether it's at home, in the car, at Field Day, or for portable operation — experiences the rite of passage called an *RF burn*. Although painful, it rarely creates a physical mark, just a certain wariness on the part of the burn-ee. What's happening here?

You just had an exciting encounter with a high-impedance point on your antenna system. Impedance being the ratio of voltage to current, when power is applied, a high RF voltage will be present at these points. Who says you can't feel RF? "But wait," you exclaim, "the antenna is up in the air and connected to the antenna tuner! I'm not touching my antenna system!"

Oh yes, you are! Unless your station is built inside an RF-tight metal enclosure or is otherwise isolated from the antenna and feed line, every coax shield, every enclosure,

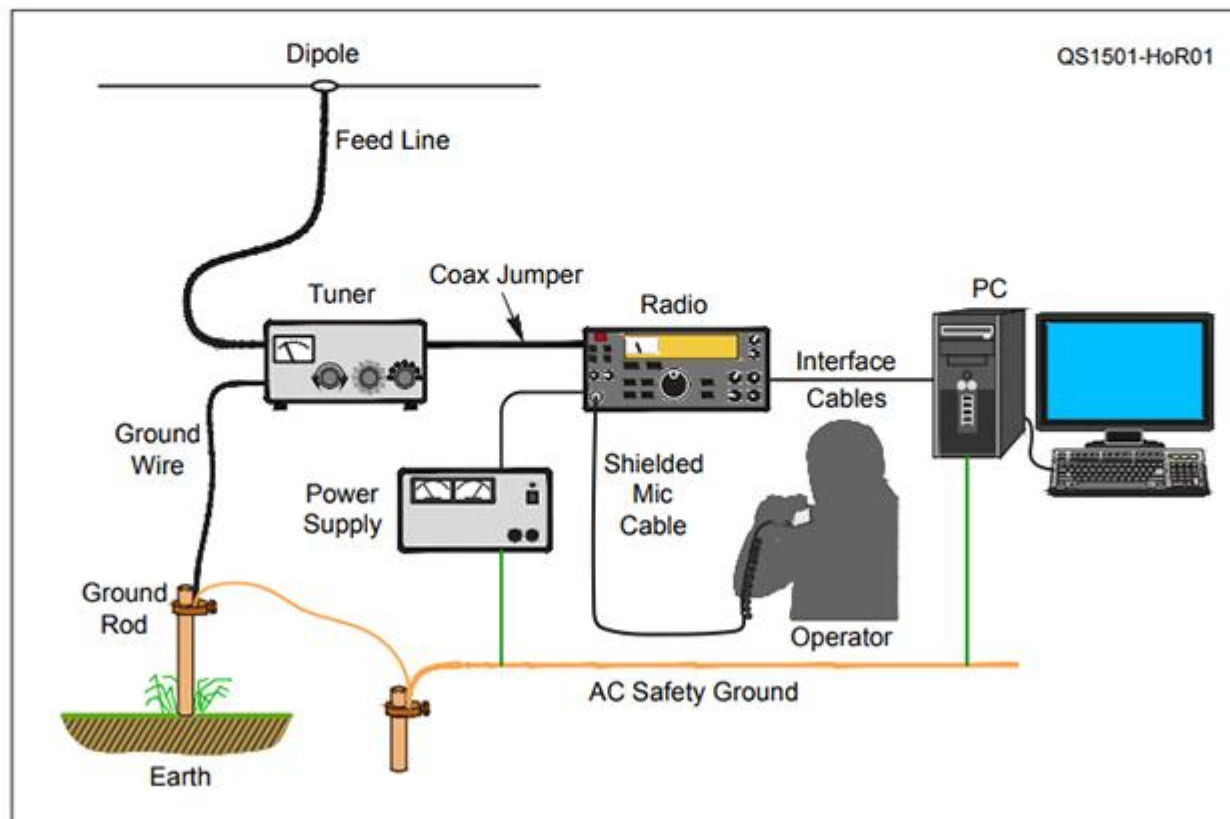

**Figure 1** — The complete antenna system for a typical shack. Everything conductive, including the operator holding a microphone, is part of the antenna system.

**January  
2015 QST  
H. Ward  
Silver**

**No Such  
thing as a  
“Perfect”  
RF Ground**

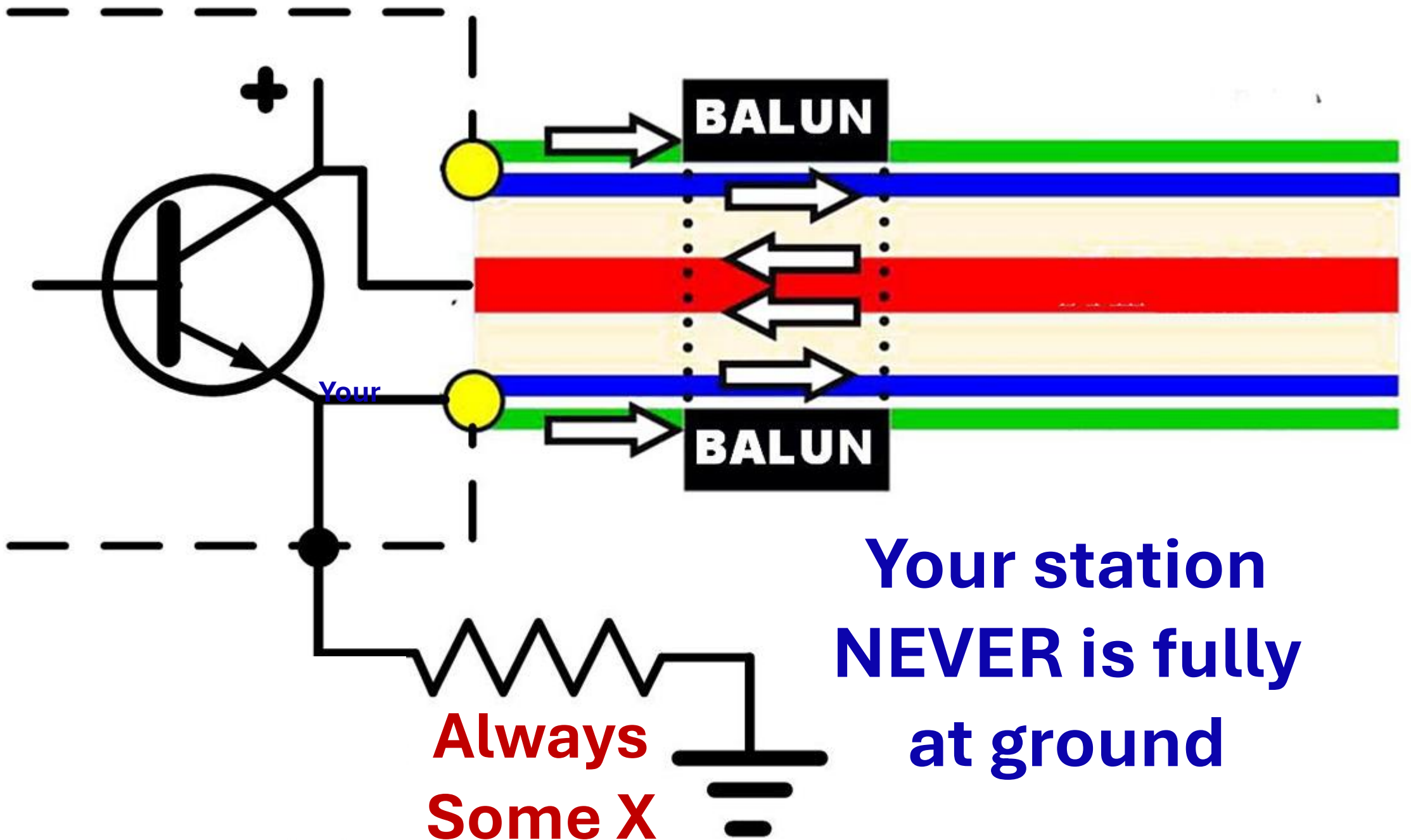

**BALUN**

**BALUN**

Your

**Always  
Some X**

**Your station  
NEVER is fully  
at ground**

**Jim W6OEK's  
experience with an  
80-meter OCF dipole  
with a good balun**

# Conductive Fabric Didn't Work



**Only shield current  
chokes**

**in the shack worked**

# Ferrite Sleeves



# Ugly/Coax Balun



# Toroid Balun



# Ferrite Snap-On's



**Mix 43/31 HF, 61 VHF/UHF**

**1 — 10m, dozen — 160m**



# A Non-Double-Choked System is an RF Magnet

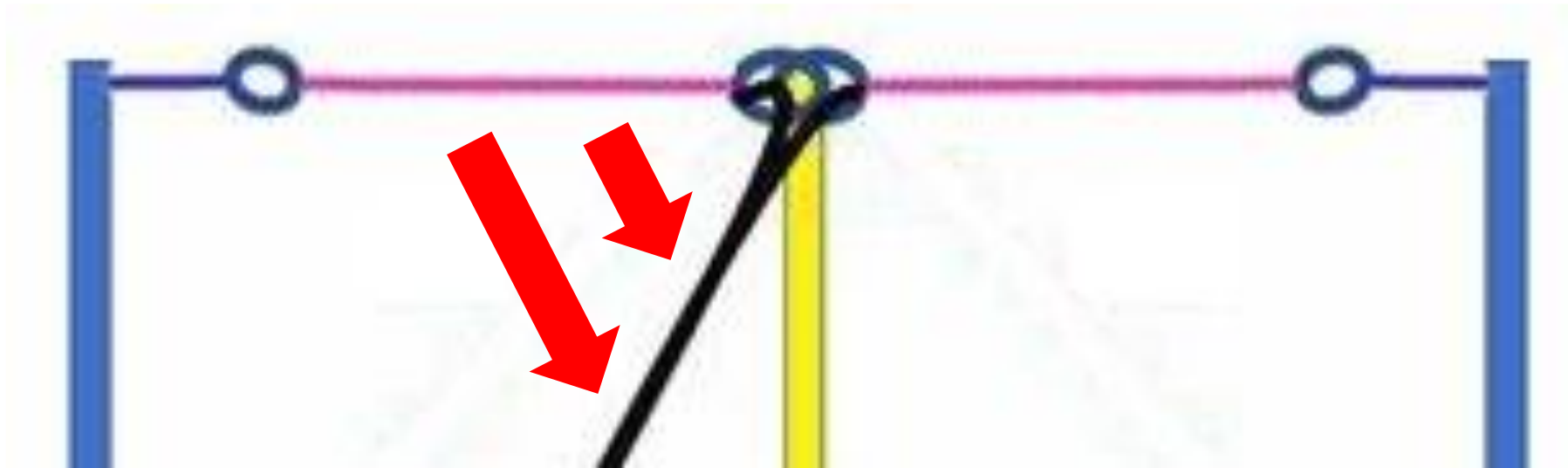

**Your own feedlines not at 90°**

# A Non-Double-Choked System is an RF Magnet

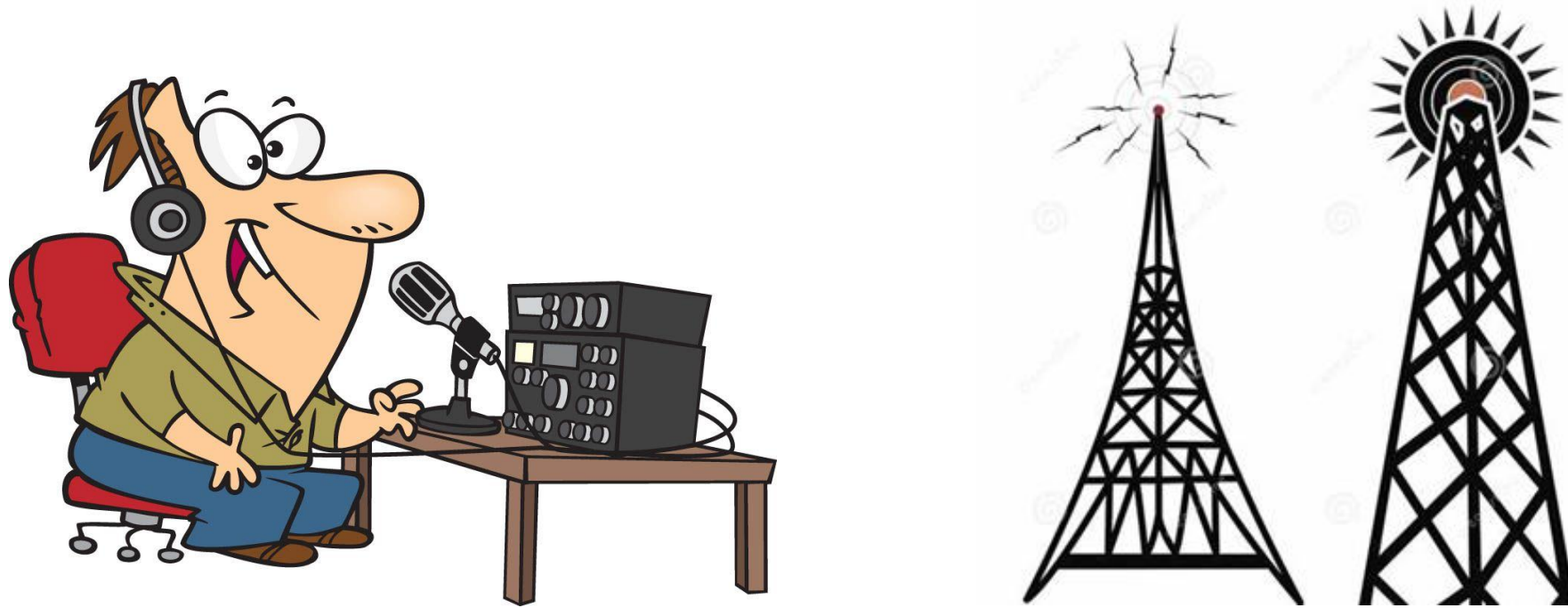

**Other Transmitters**

# **A Non-Double-Choked System Is an RF Magnet**



**Atmospheric, Industrial Noise**

*My Manta*

**Choke, Choke, Choke**

- **Transmitters**
- **Coaxes – Both TXs & Antennas**
- **More than one balun is OKAY**

Also with a 4:1 or 9:1

# LDG

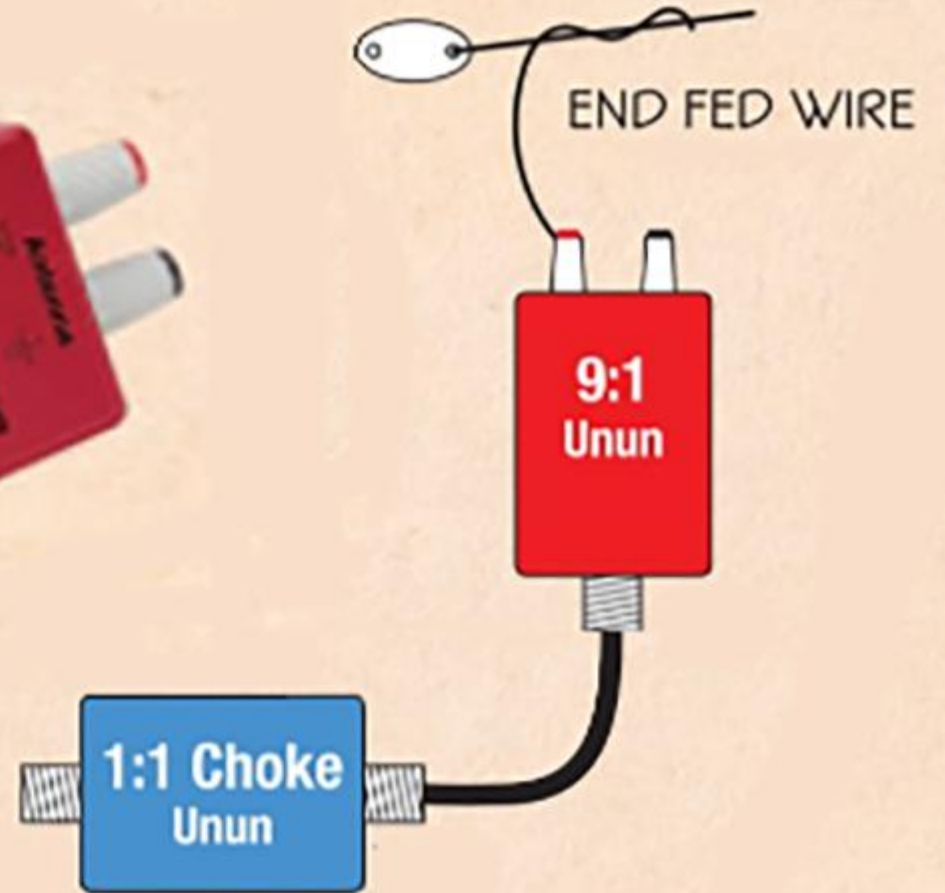



[w6nbcmail@  
gmail.com](mailto:w6nbcmail@gmail.com)  
[w6nbc.com](http://w6nbc.com)



**DØGGY**

*"That's all Folks!"*